

Thermoelectric Module (TEM) Peltier Element Mounting Procedure

February 26, 2007



1590 Keane Drive
Traverse City, MI 49686 USA
<http://www.tetech.com>

Phone: (231) 929-3966
Fax: (231) 929-4163
e-mail: cool@tetech.com

All Materials Copyright © 2007, TE Technology, Inc.

1. “Tinning” Definition:

In these instructions, words “tin”, “tinning”, or “tinned” are generally used to discuss a process in which a thin coating of solder is applied to an uncoated metal surface to prevent corrosion of the base metal and prepare it for future soldering operations. The root word (in the English language) was originally derived when metal workers used the elemental metal Tin to coat other metals. However, for the purposes of this article, and in technical literature in general, it has been expanded to include the coating of a metal with any of the solders listed.

2. Solder Types:

Thermoelectric (Peltier) modules are made with several different types of internal solders, depending on the requirements for the maximum operating temperature of the module:

Module Temperature Range	Maximum Operating Temperature	Internal Solder Type	Solder Melting Point, °C
Standard (TE, HP, CH, etc.)	80 °C	58/42 Bi/Sn	138 °C
HT-series	150 °C	63/37 Sn/Pb	183 °C
VT-series	200 °C	95/5 Sn/Sb	232 °C

The solders discussed in this guide can be purchased from the Indium Corporation (www.indium.com) as well as other sources.

If you have removed the wires from a module so that you can attach your own wires, or if the modules did not come supplied with wires, you should take caution in choosing the solder for attaching the new wires to the module. Always use the same type of solder as used in the internal construction of the device. Do not mix solder types.

Most modules come with stranded wire leads (some though might have solid wires with no tinning). If the ends of the wires are tinned, the solder used for tinning is the same type of solder as used for the internal solder of the module. So, if you need to extend the wire length, you should either use the same type of solder when making a soldered wire splice or you should clip off the tinned portion of the wire first before using a different solder to make a soldered wire splice. Of course, if the wire leads do not have any tinning, you can choose any solder that is suitable for your needs or simply not tin the ends at all.

Whenever your soldering process will heat the thermoelectric elements, whether in tinning a module’s substrate or in attaching wires, soldering exposure time should be limited as much as possible. Note that the internal solder of the module will reflow if overheated, so if you inadvertently heat the module at or above this temperature, you can cause permanent damage to the module. Furthermore, the solder in standard modules also contacts the thermoelectric elements directly—there are no Nickel diffusion barriers on the ends of the elements as in VT or HT series modules. The solder in standard modules can migrate within the thermoelectric material even if the

solder does not reflow. So, it is always a good idea to minimize the exposure of a module to elevated temperatures.

3. Physical orientation of the module:

The thermoelectric (Peltier) effect of a module is completely reversible. If the direction of the current through a module is reversed the heat flow through the hot and cold sides will also reverse. Thus, what was the cold side will now become the hot side, and what was the hot side will now become the cold side. That said, one may then wonder why there is a “hot side” and a “cold side” of a module.

The answer has to do with the heat that is conducted through the wires. The ends of the wires that are attached to the power source will be at or near ambient temperature. If those wires go to the cold side of a module, heat will be conducted from the warm end of the wires into the cold side. Copper is an excellent conductor of heat! That parasitic heat load robs the module of some of its useful cooling capacity. So, by placing the wires on the hot side this loss is eliminated.

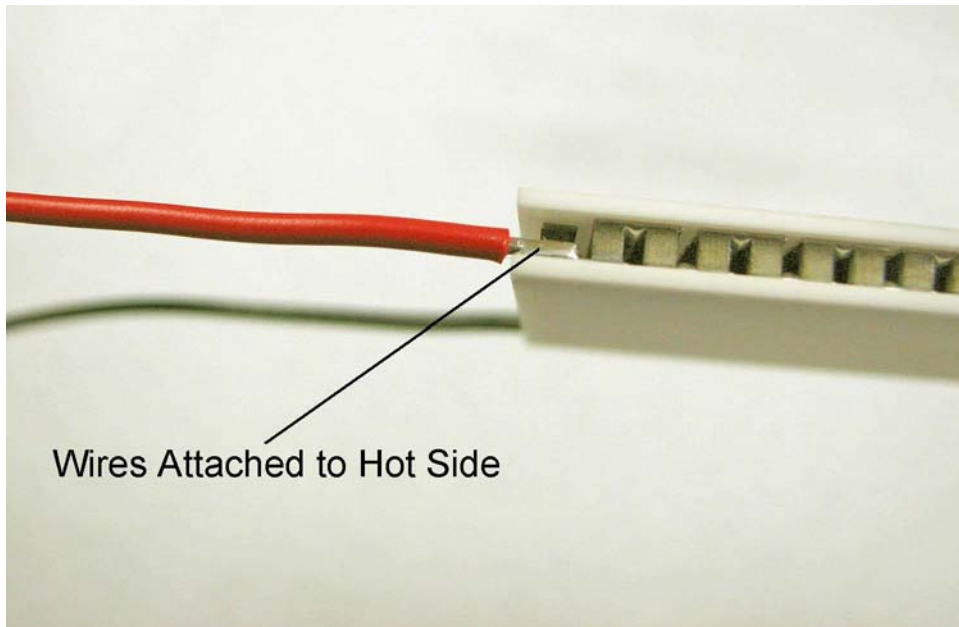

4. Locating the Positive Wire:

If the module has a red and a black wire, locating the positive wire is simple—the red wire is the positive lead. Positive current flowing into this wire will cause heat to flow from the cold side of the module into the hot side of the module.

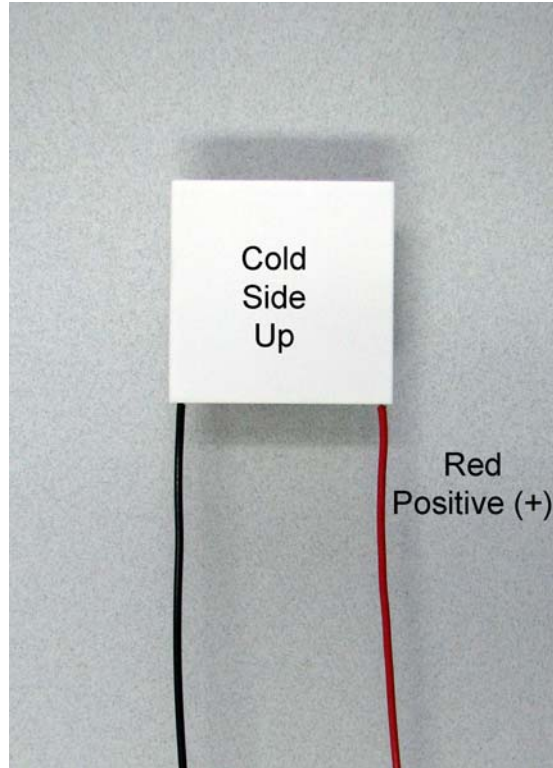

If the module has one substrate that is wider than another, as with some micro modules, the answer is again simple because the hot side of the module is the larger of the two sides. Once you know which side is the hot side all thermoelectric modules follow the same wire convention: the positive wire is always on the right side wire when the hot side of the module is placed down on a table and both wires are pointing towards you.

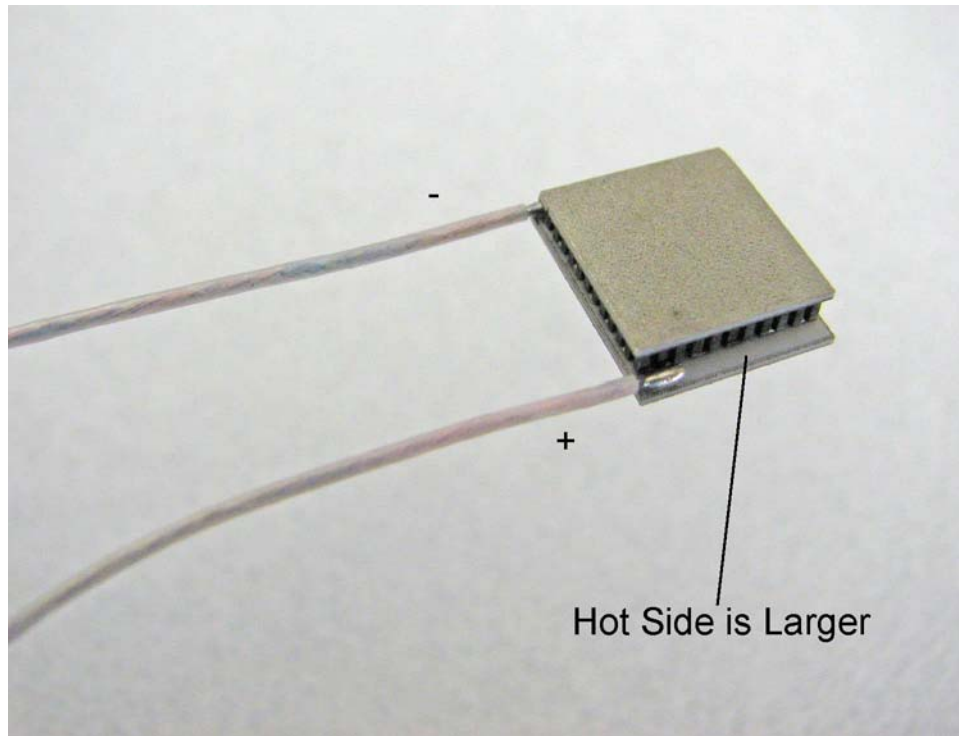

Finally, if there is no red wire, such as in the case of micro modules, or if there are no wires at all, then you will need to determine on which side of the module the wires enter. As previously described, the wires are always attached to the hot side of the module. This is easy to see on thick modules, and more difficult for thinner modules. Looking from the side of the module is usually the easiest way. The wires will be closer to the hot side of the module. If you are uncertain, you may need to examine the module with a magnifying lens. Look closely to where the wires enter the module. Again, the wires always enter the hot side. Next, if you place the thermoelectric module on a table with the hot side on the table (cold side facing up) and the wires point towards you, the right side wire is positive.

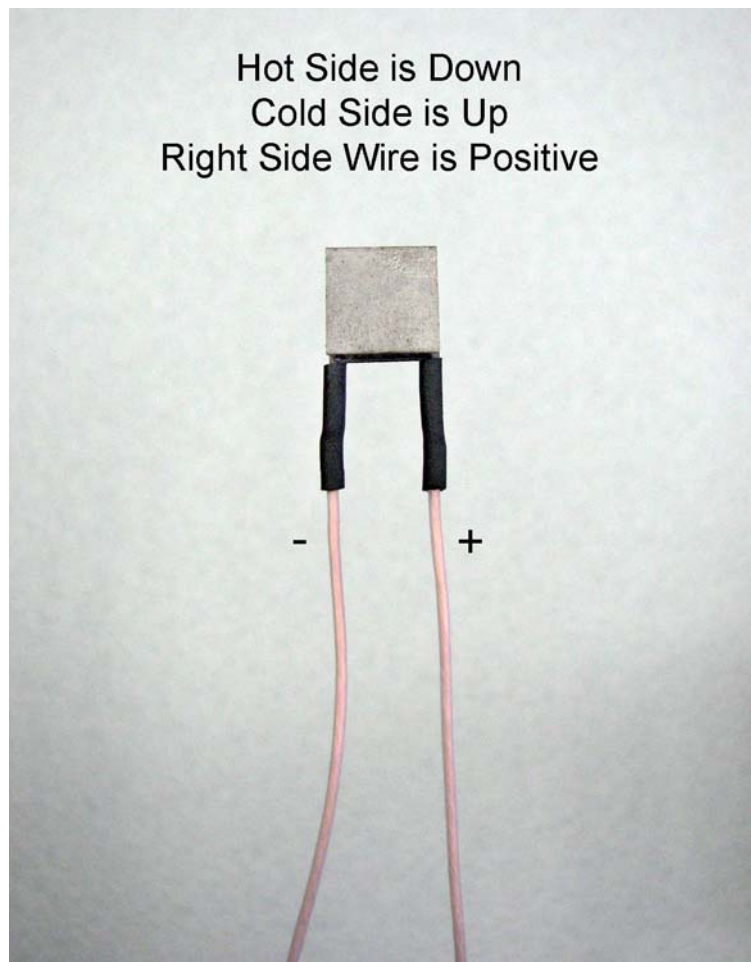

5. Procedure for Mounting Modules with Thermal Paste:

1. Make sure the module-mounting surface is sufficiently flat. The surface should be flat within 0.025 mm across all of the mounting area that the module(s) will encompass. There should be no readily detectable ridges left by the metal surfacing equipment.

2. If using more than one module in the assembly, ensure that the modules share a common height within 0.025 mm.
3. Prepare cold plate and heat sink screw holes: Locate screw holes at opposite ends of the module. They should be at a minimum of 4 mm up to a maximum of 15 mm away from the edge of the module, as shown below. Drill a clearance hole through one plate (no threads), and drill and tap the other plate accordingly (hole with threads). If the heat exchanger has fins, locate the screw holes in the same plane line as the heat exchanger fins. This orientation utilizes the additional structural strength of the fins to prevent the heat exchanger from bowing (bending) under the compression force.

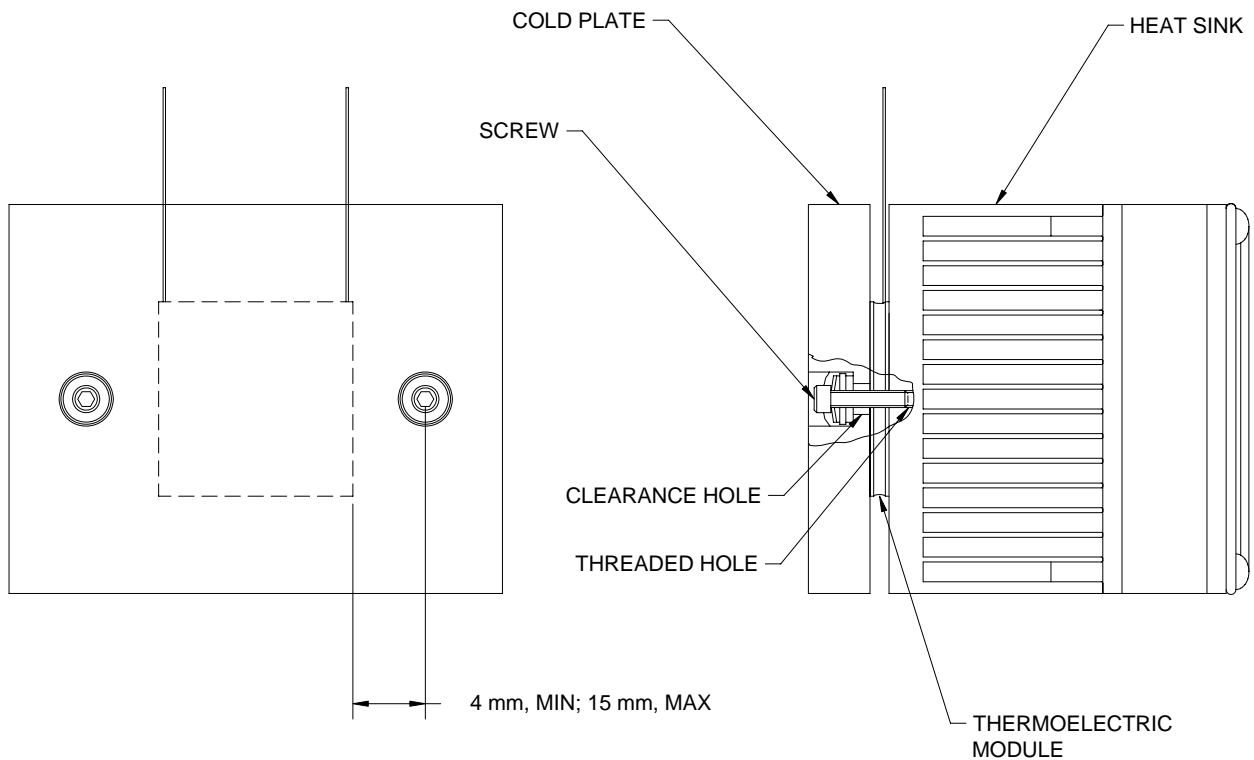

4. Remove all burrs, chips, and foreign matter from the thermoelectric module-mounting area. Thoroughly clean the thermoelectric module, heat-sink, and cold-plate surfaces.
5. Apply a thin, continuous film of thermal paste to the hot side of the module and to module-mounting area on the heat sink. Place hot side of the module onto the heat sink.

6. Gently move the module a small amount back and forth while exerting uniform downward pressure. Continue this motion until you feel resistance. This will work out most of the excess thermal paste between the module and the heat sink.
7. Repeat step #5 for cold side of the module and the module-mounting area on the cold plate.
8. Position cold plate on module.
9. Compress the assembly by hand to seat the cold plate onto the module.
10. Apply lubricant to the screw threads, and install the screws and washers. Use stainless steel screws, spring washer(s), flat washers and fiber shoulder washers, stacked up as shown below:

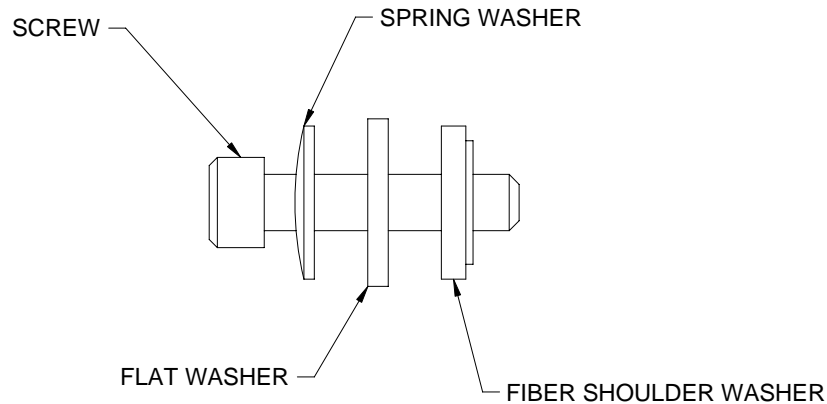

The recommended compression for the thermoelectric module is as follows.

Type of Module:	Suggested Compression Pressure:
Standard	500-1200 kPa, 70-170 psi
High Performance	800-1200 kPa, 120-170
Micro	200-600 kPa, 30-90 psi
Multistage	300-1000 kPa, 40-150 psi

You must calculate how much screw torque is needed to achieve this compression force. The equation is as follows:

$$T = \frac{c \times D \times P \times A}{N}$$

T = torque per screw (lb-in. or N-m)

c = torque coefficient

D = nominal screw size (in. or m)

P = compression pressure (Pa or psi)

A = total area of module footprint (in.² or m²)

N = number of screws

The torque coefficient will vary as a function of the screw size used and on the friction of the screw threads and washer stack up. Common screw sizes are shown below with the corresponding nominal diameter and typical torque coefficient. Be sure that the variable inputs use the units as indicated above.

Screw Type	Nominal Diameter	Torque Coefficient, (c)
2-56	0.086 in.	0.15
4-40	0.112 in.	0.15
6-32	0.138 in.	0.15
8-32	0.164 in.	0.15
M2 x 0.4	0.002 m	0.15
M3 x 0.5	0.003 m	0.14
M3.5 x 0.6	0.0035 m	0.14
M4 x 0.7	0.004 m	0.15

For example, suppose you have two HP-199-1.4-1.5 modules, and you want 1200 kPa pressure, and you are using three M3 x 0.5 screws. Each module is 40 mm x 40 mm. Therefore you have the following:

c = 0.14

D = 0.003 m

P = 1,200,000 Pa

A = 0.04 m x 0.04 m + 0.04 m x 0.04 m, (or, 2 x 0.04 x 0.04)

N = 3

$$T = \frac{0.14 \times 0.003 \times 1200000 \times 2 \times 0.04 \times 0.04}{3} = 0.54 N \cdot m$$

Consider a similar example in English units where you want to achieve 170 psi compression using three 6-32 screws. Thus,

c = 0.15

D = 0.138 in.

$$P = 170 \text{ psi}$$

$$A = 40/25.4 \text{ in} \times 40/25.4 \text{ in} + 40/25.4 \text{ in} \times 40/25.4 \text{ in}, \text{ (or } 2 \times 40/25.4 \times 40/25.4)$$

$$N = 3$$

$$T = \frac{0.15 \times 0.138 \times 170 \times 2 \times 40/25.4 \times 40/25.4}{3} = 5.8 \text{ lb} \cdot \text{in}$$

You should verify that you have a sufficient number of screws such that the total load per screw does not exceed the load limits of the screw or threaded hole. Be sure to use a spring washer (or multiple washers) that can handle the load.

Next, torque the assembly screws using a torque-limiting screwdriver. Set the initial torque limit of the screwdriver at some value that is less than the torque setting just calculated. The initial torque setting will depend on the particular assembly requirements; you might try half, a third, or even less. If there are only two screws tighten them in alternating steps until the final torque setting is reached. The object is to torque the screws evenly so that the cold plate is seated flat against the module. If there are three or more screws start tightening the screws located in the center of the plate and work outward, alternating between screws. Increase the torque setting by some amount and repeat the tightening process. Again, continue this sequence until you reach the final torque setting.

This sequence is required to ensure that the modules receive only a compressive force, never a tensile force that might otherwise occur with unevenly applied torque on assembly screws. If the compression on the module is not even the module can be damaged and the thermal interface will not be good.

11. Be careful not to bow the surfaces of the heat sink and/or cold plate as this will prevent good thermal contact between the module and cold-plate/heat-sink surfaces. To prevent bowing, apply less torque, particularly if one or both surfaces are less than 4 mm thick copper or 6 mm thick aluminum.
12. Re-torque at the calculated torque setting after one hour. The thermal paste is very viscous, and some will squeeze out after time. This causes a loss of compression. Re-torquing allows the compression to be brought back up to the original level and will help expel any excess thermal paste that is still remaining.

6. Procedure for Mounting Modules with Solder:

Metallized modules do not necessarily need to be soldered to a mounting surface. Provided they are not tinned, they can be mounted like any other non-metallized module. If you do not want to solder, consult the "Procedure for Mounting Modules with Thermal Paste" above.

When tinning the metallized substrate of a module, TE Technology recommends using a solder with a melting point as low as possible. This helps to prevent inadvertent reflowing of the internal solder of the module. The melting point of the mounting solder should be at least 10 °C lower than the melting point of the internal solder. A 20-30 °C, or even larger difference, in melting points is preferable.

Never allow any of the solder used for tinning the substrates to mix with the internal solder of the module. Small balls of solder could separate from the solder used for tinning the module and diffuse into the internal solder--this can cause both immediate and latent failure. Care must be taken to avoid this by not using excessive solder when solder mounting modules.

Caution! Soldering a module to a heat sink or cold sink can induce severe thermal stresses as the result of mismatches in the coefficients of thermal expansion (CTE). These stresses can crack the solder junctions within a thermoelectric module causing a loss of thermal performance and electrically open circuits. The amount of stress is relative to the amount of mismatch in the CTE between the substrate and the mounting surface, the physical size of the module, the freezing point of the solder, and the operating and storage temperatures of the completed assembly. For micro-modules, these stresses are less of a concern than with larger modules because the physical size is smaller, but they are still a concern nonetheless. For the best reliability, modules should not be soldered down. Furthermore, soldering on both sides of a module can induce even more problems. When solder alone is used to constrain the module, all gravity-related forces and shock-and-vibration stresses are born solely by the module. This should be kept in mind when considering how to mount modules.

Always thoroughly test a new assembly design through a complete life cycle of power, thermal, and storage temperature, and shock and vibration cycles before finalizing on a design to be manufactured in production quantities. Verify proper thermal performance can be achieved before and after testing. TE Technology, Inc. does not warrant modules against failure due to thermal cycling, power cycling, or mechanical damage.

6.1 Instructions when soldering mounting on one surface and paste mounting on the other:

Soldering the first side:

1. Prepare cold plate and heat sink plate by drilling clearance holes in one plate and drilling and tapping the opposite plate accordingly. For purposes of discussion, it is assumed that the hot side of the module(s) will be soldered to the heat sink and the cold plate is clamped to the module(s) using assembly screws.
2. Make sure heat-sink plate surface is flat within 0.025 mm across all of the mounting area that the module(s) will encompass.
3. Tin the heat-sink plate surface with an appropriate solder such as 96 °C solder (52% Bi, 30% Pb, 18% Sn).

4. Scuff the nickel plating on the hot side of the module with fine sand paper to expose fresh metal if necessary, and then clean the plating. Tin the hot side of the module with the same solder used in Step 1.
5. Solder the module to the heat sink: Apply a small amount of flux to the pre-tinned module-mounting surface. Heat the heat sink so that the solder just begins to melt (approximately 20 to 30 °C warmer than the solder's melting temperature). Place the pre-tinned hot side of the module on to the plate surface. Wait a few seconds for the solder on the module to melt and for the excess flux to boil out. When all the solder is molten, the module will "float" on the solder. Lightly move the module back and forth a small amount to ensure complete wetting of the solder. Then press the module down on to the plate to minimize the thickness of the solder layer, and then allow the assembly to cool. Again, do not allow any solder balls that are squeezed out from beneath the module to mix with the internal solder of the module.

NOTE: If you are using more than one module in the assembly, all of the modules must be soldered down such that the cold sides of the modules are coplanar within 0.025 mm.

6. After the assembly cools, clean thoroughly to remove all traces of flux residue.

Paste mounting the other side:

7. Apply a thin continuous film of thermal paste to the cold side of the module(s) and to the corresponding cold plate area.
8. Lower the cold plate on to the modules and gently move the cold plate back and forth, exerting a uniform downward pressure. Continue this motion until you feel resistance.
9. Clamp the assembly together carefully using the screws. Apply torque to the screws in small increments, alternating between screws. Use stainless steel screws, spring washers, steel flat washers and fiber-insulating shoulder washers. Use a torque-limiting screwdriver. Use the same calculations and procedures as described above in Section 5.
10. Be careful not to bow the mounting surfaces, as this will prevent good thermal contact and may damage the module. Apply less torque if one or both surfaces are bowing. For best results, use a mounting surface that has a minimum flexural rigidity equivalent to 6 mm thick copper or 10 mm thick aluminum.
11. Re-torque the assembly screws a minimum of one hour after initial tightening.

6.2 Instructions when soldering module on both surfaces:

1. Tin all heat-sink, cold-plate, and module surfaces as in Section 6.1, steps 2 and 3 above.
2. Solder the module to the heat sink: Apply a small amount of flux to both sides of the pre-tinned module. Heat both the heat sink and cold plate to approximately 20-30 °C above the melting point of the solder. Place the module between the heat sink and cold plate. Wait a few seconds for the solder on the module to melt and for the excess flux to boil out. When all the solder is molten, lightly move the module back and forth a small amount to ensure complete wetting of the solder. Compress the

heat sink on the modules to minimize the thickness of the solder layers, and then allow the assembly to cool.

3. After the assembly cools, clean thoroughly to remove all traces of flux residue.