

LC-061 Peltier-Thermoelectric Liquid Cooler

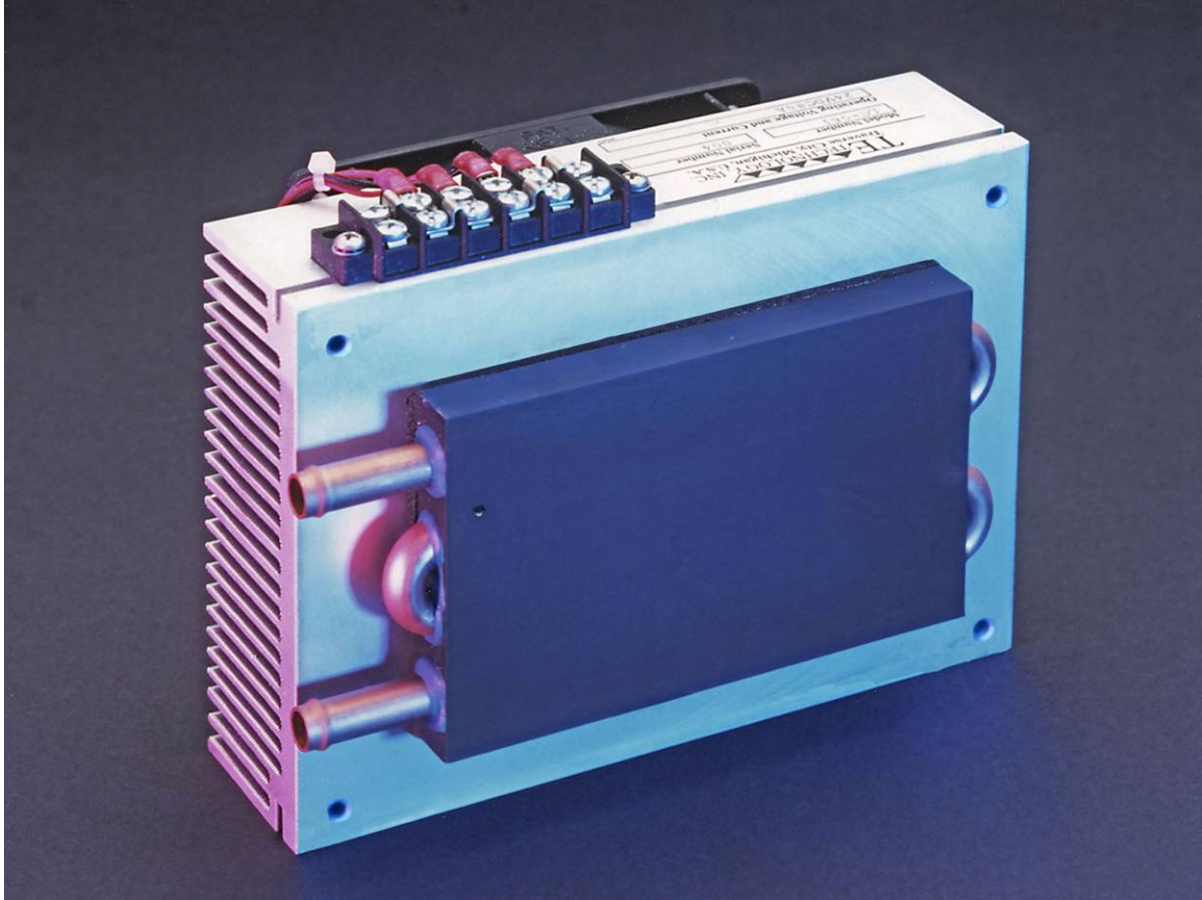

- A high-density extruded heat sink and a four-pass liquid exchanger provides good cooling capacity in a relatively small size.
- Useful for small-to-medium heat loads in medical products, laser diode coolers, laboratory instruments, gas-stream dehumidification, etc.
- Can be customized with swirl inserts in the liquid loops to improve heat transfer at low flow rates.
- Threaded hole located in liquid exchanger provides for easy attachment of a temperature sensor.
- The cooler can easily be customized for production-sized orders to meet your exact requirements.
- CE marked, RoHS compliant

TE TECHNOLOGY, INC.

1590 Keane Drive
Traverse City, MI 49696-8257
www.tetech.com

TEL: 231-929-3966
FAX: 231-929-4163
email: cool@tetech.com

LC-061 Specifications

TE Power (typical) ¹ :	24 VDC at 4.5 A	NEMA Rating:	not applicable
TE Power (maximum) ² :	24 VDC at 5.5 A		
Hot-side Fan Power:	24 VDC at 0.34 A	Weight (kg):	2.0
Please review the product manual: <i>Thermoelectric Cooling Assembly (TCA) Instruction Manual</i> , FAQ's and related technical information, and ordering information posted on our web site before purchasing or using this product.		Performance is based on unrestricted air flow to fan and from air-flow outlets and 1.6 L/min water flow rate through heat exchanger. Do not operate if the ambient, liquid, heat sink, or cold sink temperatures exceed 70 °C. Do not operate at air temperatures below -10 °C. Do not freeze the liquid. Do not exceed 205 kPa water pressure.	

¹Current, at steady state, is rated at +25 °C ambient, +25 °C inlet water, maximum heat removal. At 5 °C inlet, the typical steady-state current is 4.4 A.
²Current, at steady-state operation under-worst case conditions, is rated at -10 °C ambient, +70 °C inlet, maximum heat removal.

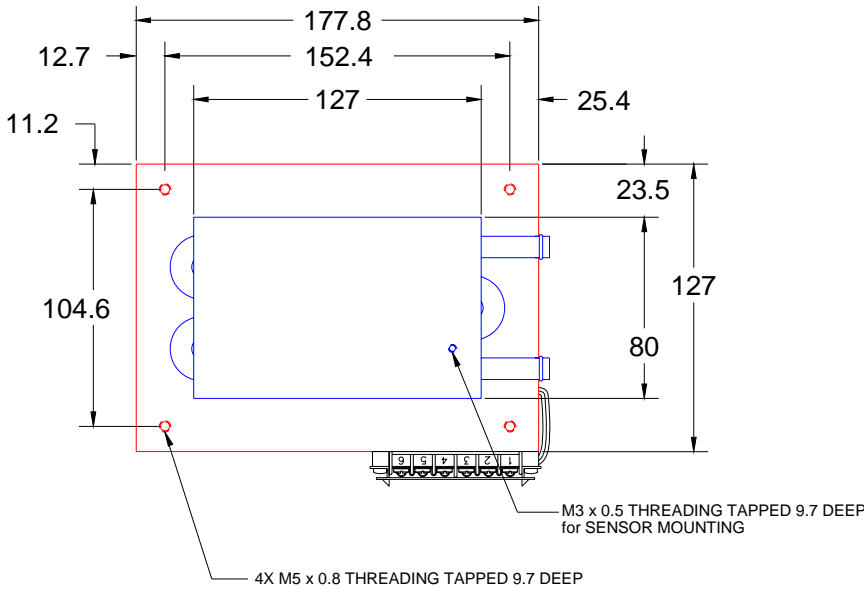

NOTE: 1. ALL DIMENSIONS ARE IN MILLIMETERS
 2. COLD SIDE SHOWN IN BLUE;
 HOT SIDE SHOWN IN RED

A 3D PDF is also available from the website. Contact TE Technology for 3D solid models in STEP, SAT, or STL format.

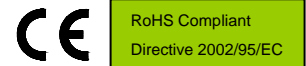
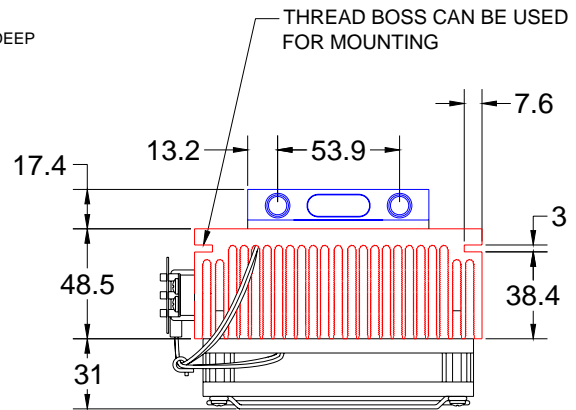
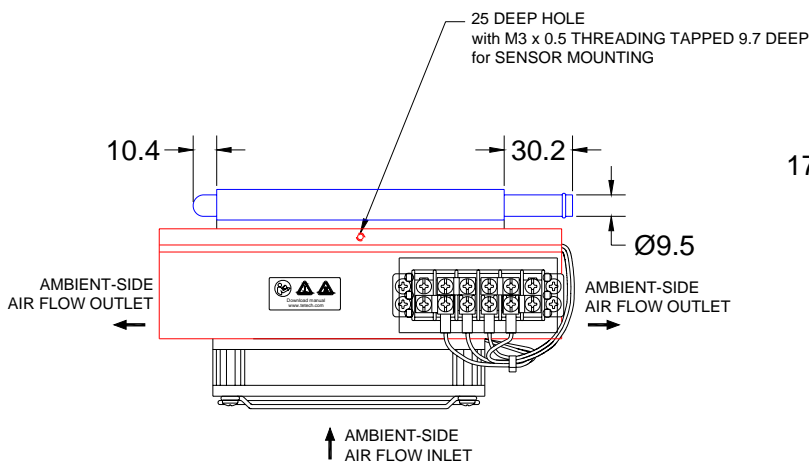

1590 Keane Drive
 Traverse City, MI 49696-8257
www.tetech.com

TEL: 231-929-3966
 FAX: 231-929-4163
 email: cool@tetech.com

LC-061 Cooling Performance Graph

(removing heat from water, flowing at 1.6 L/min)

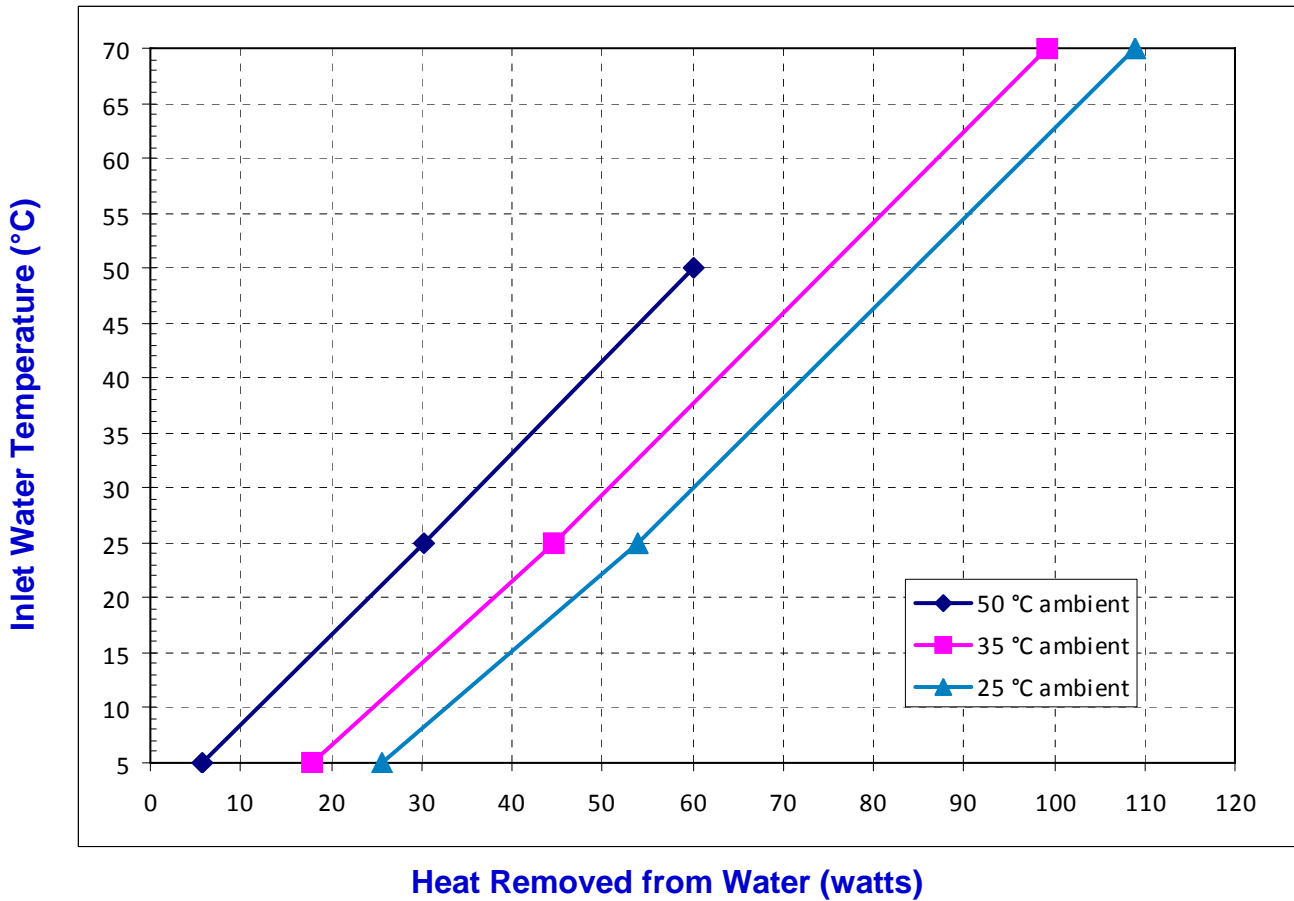

How to use the Performance Graph:

1. Select Performance Line.

The diagonal lines shown represent cooling performance at the indicated ambient air temperature (inlet to ambient-side fan). If the cooler is to operate at a different ambient, then you must sketch in a new performance line. This can be drawn parallel to one of the existing lines, using the distance between the existing lines as a scale to properly locate the new line. →

2. Select Enclosure Temperature.

Draw a horizontal line on the graph corresponding to the desired inlet water temperature until it intersects with the performance line corresponding to the ambient temperature at which the cooler is to operate.

NOTE: heating performance is not shown. Contact TE Technology, Inc. if you require this information. →

3. Determine Cooling Capacity.

The maximum amount of heat that the cooler can remove from the water is determined by the intersection point (determined in the previous step). *If the heat load exceeds the cooling capacity, then the cooler will not be able to maintain the desired water temperature. If the heat load is less, then the cooler can operate with less input power.*

Example: You need to maintain the water at 15 °C while in a 25 °C ambient. The cooler can remove a maximum of approximately 40 W of heat from the water. If the heat load (internally generated heat plus the heat gain through insulation, solar, vapor condensation, etc.) in the water exceeds this, you would need more coolers and/or a larger cooler.

TE TECHNOLOGY, INC.

1590 Keane Drive
Traverse City, MI 49696-8257
www.tetech.com

TEL: 231-929-3966
FAX: 231-929-4163
email: cool@tetech.com