

CP-110 Peltier-Thermoelectric Cold Plate Cooler

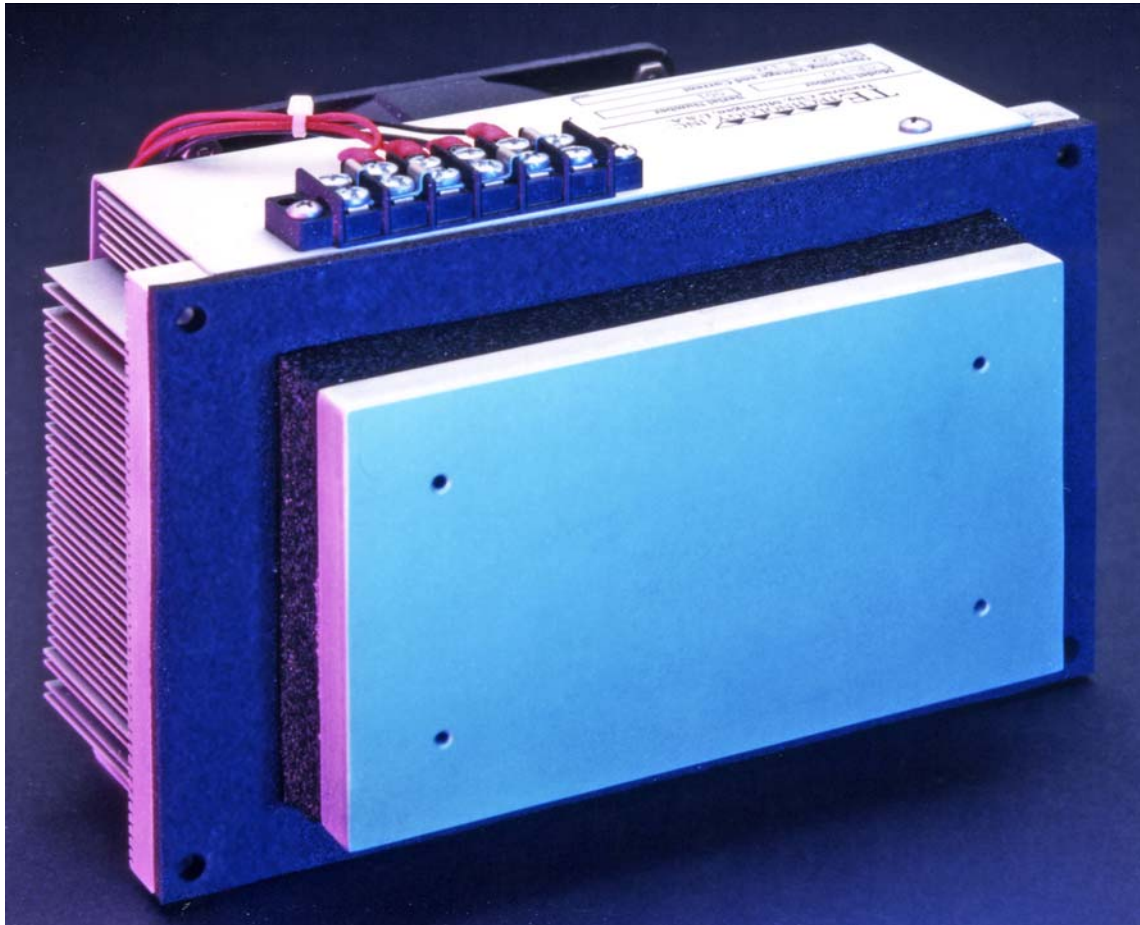

- Useful for medium sized heat loads.
- Stainless steel liquid heat exchanger (LC-SSX1) can be attached for cooling corrosive liquids.
- Provides effective direct-contact cooling which is ideal for precision temperature control.
- Efficient bonded-fin heat sink keeps cooler small but effective.
- Threaded holes are located in the cold plate for easy attachment of a temperature sensor, interface plates, and other cooled plates.
- High-temperature version and other customizations are available upon request.
- CE marked, RoHS compliant.

TE TECHNOLOGY, INC.

1590 Keane Drive
Traverse City, MI 49696-8257
www.tetech.com

TEL: 231-929-3966
FAX: 231-929-4163
email: cool@tetech.com

CP-110 Specifications

TE Power (typical) ¹ :	24 VDC at 9.0 A	NEMA Rating:	NA
TE Power (maximum) ² :	24 VDC at 10.9 A		
Hot-side Fan Power:	24 VDC at 0.5 A	Weight (kg):	3.0
Please review the product manual: <i>Thermoelectric Cooling Assembly (TCA) Instruction Manual</i> , FAQ's and related technical information, and ordering information posted on our web site before purchasing or using this product.		Performance is based on unrestricted air flow to fan and from air-flow outlets. Do not operate if the ambient, heat sink, or cold plate temperatures exceed 70 °C. Do not operate fan at air temperatures below -10 °C.	

¹Current, at steady-state, is rated at +25 °C ambient, +25 °C cold plate, maximum heat removal. At -23 °C cold plate, the typical steady-state current is 8.8 A.
²Current, at steady-state operation under-worst case conditions, is rated at -10 °C ambient, +70 °C cold plate, maximum heat removal.

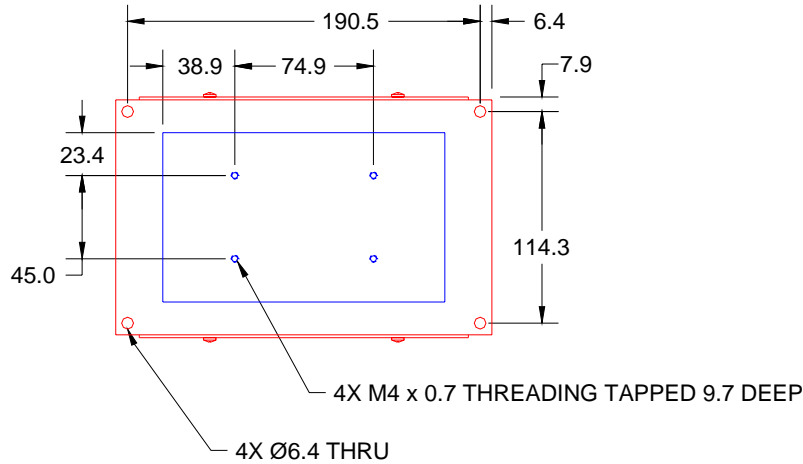

NOTES:

1. All dimensions in millimeters.
2. Cold side shown in blue; hot side shown in red.
3. A 3D PDF is also available from the website. Contact TE Technology for 3D solid models in STEP or SAT format.

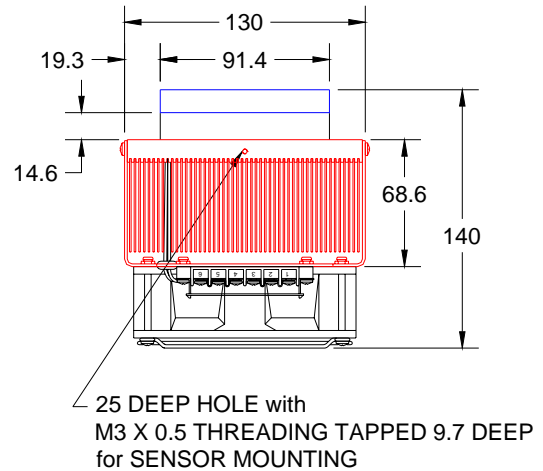
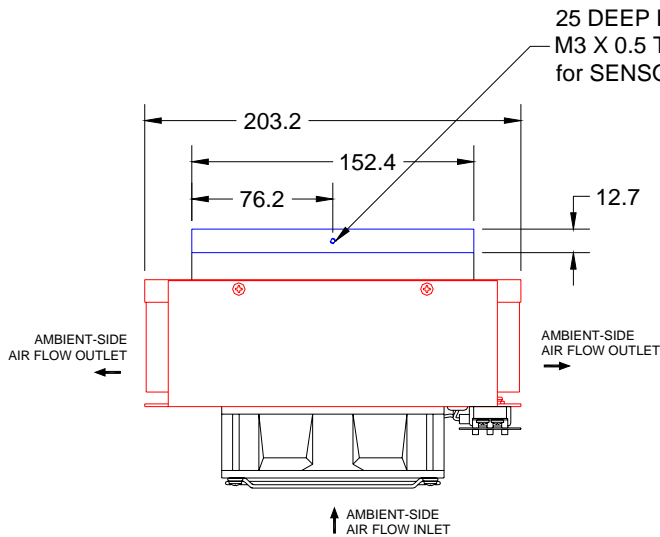

RoHS Compliant
Directive 2002/95/EC



1590 Keane Drive
Traverse City, MI 49696-8257
www.tetech.com

TEL: 231-929-3966
FAX: 231-929-4163
email: cool@tetech.com

CP-110 Cooling Performance Graph

(removing heat from cold plate)

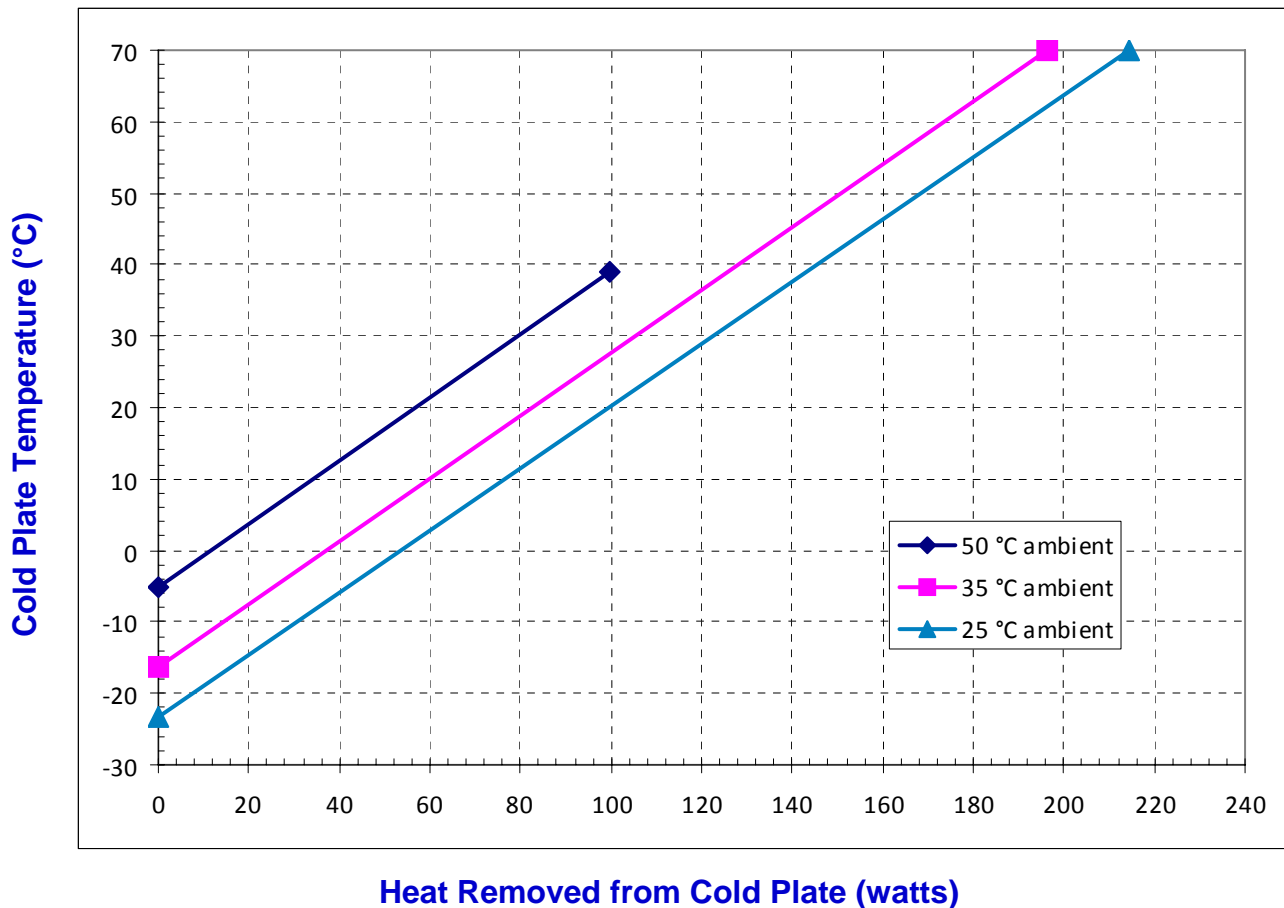

How to use the Performance Graph:

1. Select Performance Line.

The diagonal lines shown represent cooling performance at the indicated ambient air temperature. If the cooler is to operate at a different ambient, then you must sketch in a new performance line. This can be drawn parallel to one of the existing lines, using the distance between the existing lines as a scale to properly locate the new line.



2. Select Cold Plate Temperature.

Draw a horizontal line on the graph from the vertical axis corresponding to the desired cold-plate temperature until it intersects with the performance line corresponding to the ambient temperature at which the cooler is to operate.



3. Determine Cooling Capacity.

The maximum amount of heat that the cooler can remove from the cold plate is determined by drawing a vertical line from the intersection point (determined in the previous step) down to the horizontal axis of the graph. *If the heat load dissipating into the cold plate exceeds the cooling capacity, then the cooler will not be able to maintain the desired cold plate temperature.*

Example: You need to maintain the cold plate at 15 °C while in a 25 °C ambient. The cooler can remove a maximum of approximately 90 W of heat from the cold plate. If the heat load (heat source connected to the cold plate plus the heat gain through insulation, solar, vapor condensation, etc.) exceeds this, you would need more coolers and/or a larger cooler.

TE TECHNOLOGY, INC.

1590 Keane Drive
Traverse City, MI 49696-8257
www.tetech.com

TEL: 231-929-3966
FAX: 231-929-4163
email: cool@tetech.com